

DISTRIBUTED BY
INQUIP
BULK MATERIAL
& DUST HANDLING
PRODUCT • DENSITY • FLOW



Polymer Spring-loaded Pressure Relief Valves

VCP-D

SERVICE & SUPPORT

Wangara, WA +61 8 9413 1100
support@inquip.com.au
inquip.com.au



PATENT PENDING



COMPOSITE TECHNOLOGY FOR SILO SAFETY

VCP-D Pressure Relief Valves are the last resort when abnormal pressure conditions endanger the silo structure. This is why sudden excess or suction pressure inside the silo must be dealt with instantaneously. Even though a Pressure Relief Valve should ideally never have to come into action, it must work efficiently and reliably when needed.

Thousands of VCP-D Pressure Relief Valves in use worldwide are proof of absolute reliability under the most diverse conditions.

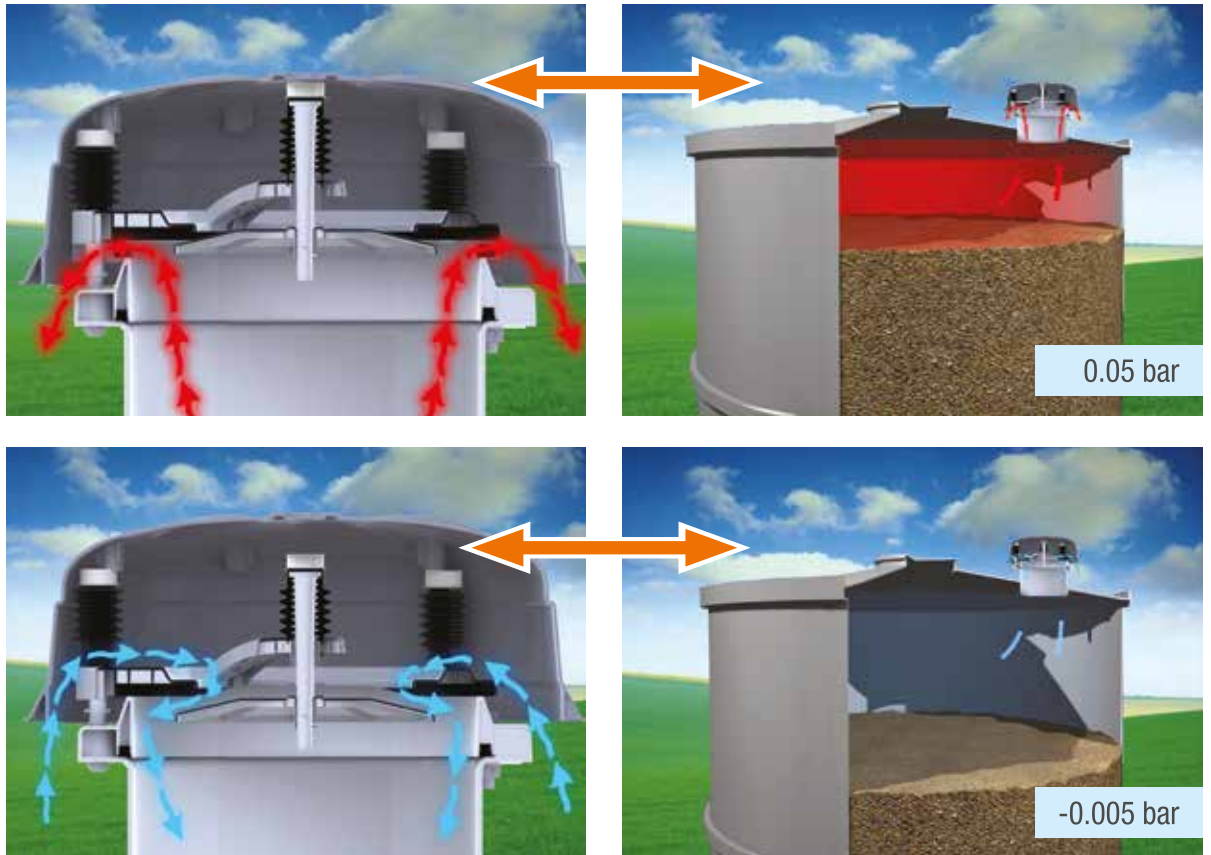

Overall Dimensions

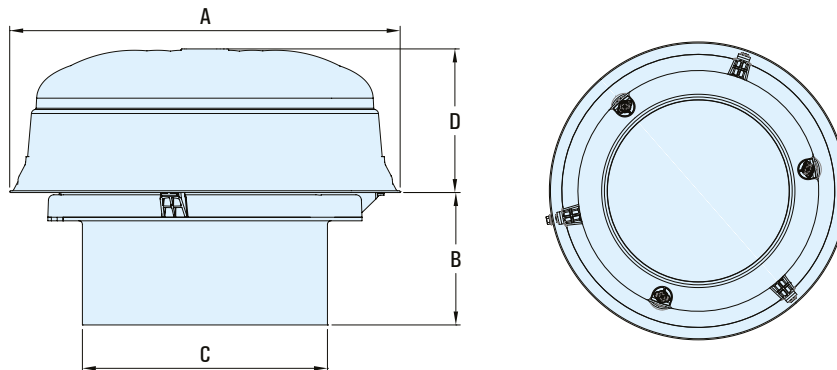

VCP-D	Excess Pressure	Negative Pressure	kg
Standard Setting	500 mm H ₂ O	-50 mm H ₂ O	6.0
Air Flow Rate	6,000 Nm ³ /h	1,900 Nm ³ /h	

A	B	C	D
Ø 435 mm	148 mm	Ø 273 mm	160 mm

Benefits



Lightweight and compact overall dimensions



Easy to fit



Technical support and worldwide availability of spare parts thanks to the WAMGROUP® subsidiary network

Technical Features

- Flow rate: up to 6,000 Nm³/h (3,530 cfm)
- Weld-on spigot in painted carbon steel
- Polymer weather protection cover
- Mechanical set-up for inductive signalling sensors
- Preset for maximum negative pressure of -0.005 bar (-0.07 psi) and maximum excess pressure of 0.05 bar (0.72 psi)

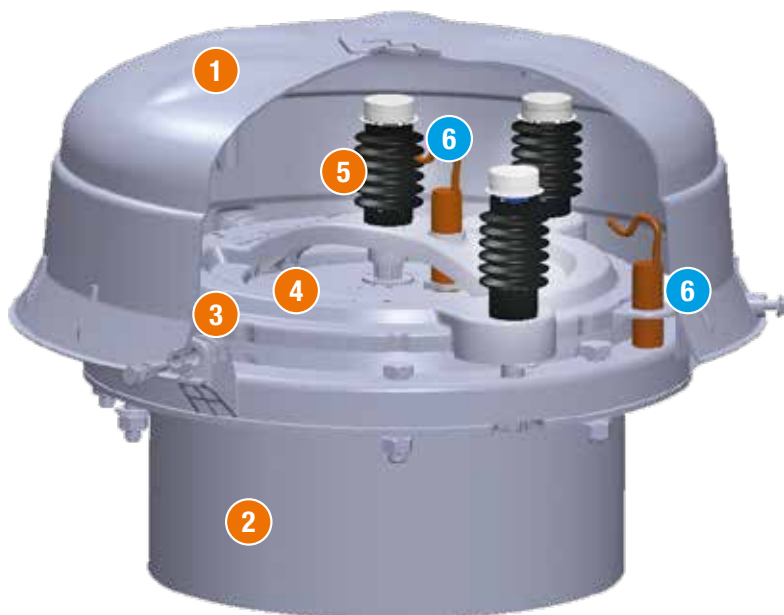

- 1 Weather protection cover
- 2 Weld-on spigot for connection to silo
- 3 Excess pressure lid
- 4 Negative pressure lid
- 5 Adjustment kit (springs)
- 6 Inductive proximity sensors (accessory)

Options & Accessories

- Different settings
- Inductive sensors
- Inspection hatch
- Bird net

Industries



Building & Construction



Plastics Processing



Dry-Mix Processing



Ceramics



Minerals

Application



203001745 April 2021 Rights reserved to modify technical specifications.

This brochure has been edited for distribution in European Union countries.



WAM VALVES



www.wamgroup.com